

Comparison of Conventional and
Alternative Project Delivery
Methods:
What's in an Acronym?

PNWS AWWA

May, 2013

Outline

- Alternative Delivery Options
- Oregon and Washington Legal Context
- Things an Owner Should Consider

Outline

- Alternative Delivery Options
- Oregon and Washington Legal Context
- Things an Owner Should Consider

There are a wide range of options to delivery projects

PROJECT DELIVERY MODEL SPECTRUM

Design
Bid - Build

Construction Manager General Contractor
(General Contractor Construction Manager)

Design /
Build

Design/Build/
Operate

Pipelines

Pump Stations

Reservoirs

Treatment Plants

\$5 - \$10 M

\$200 - \$300 M



Traditional DBB Delivery is a Well Established Process

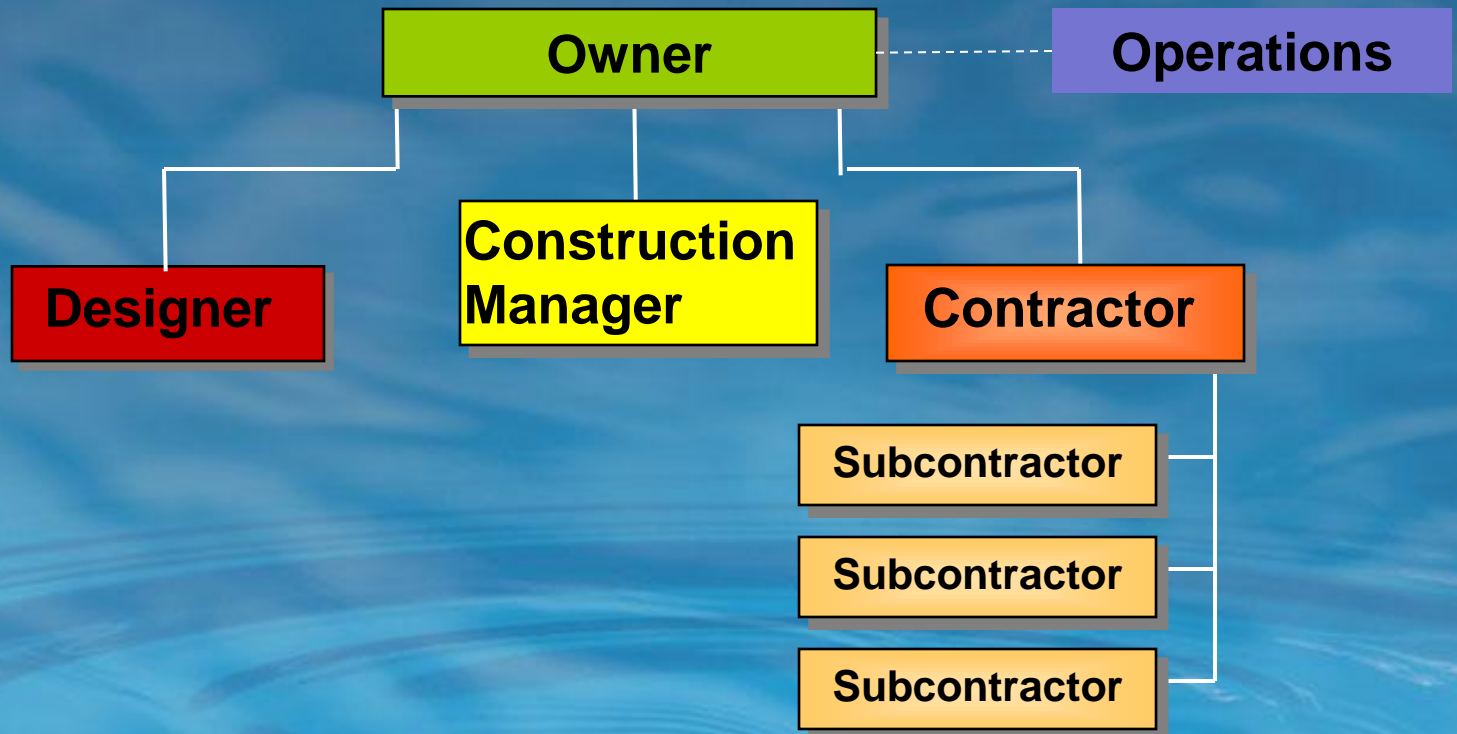

The DBB process is linear with design, bidding, construction in series

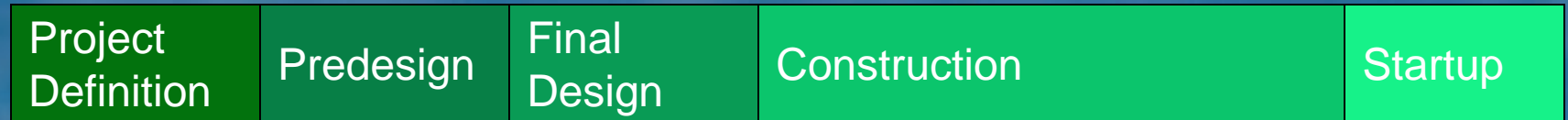

Some Problems with Traditional Delivery

- Owner holds all risk for performance and budget
- Owner in the middle of all disputes
- Low bid can lead to contentious environment or low quality
- Timeline long – can exceed project needs

GCCM or CMGC Brings Qualifications to Contractor Selection

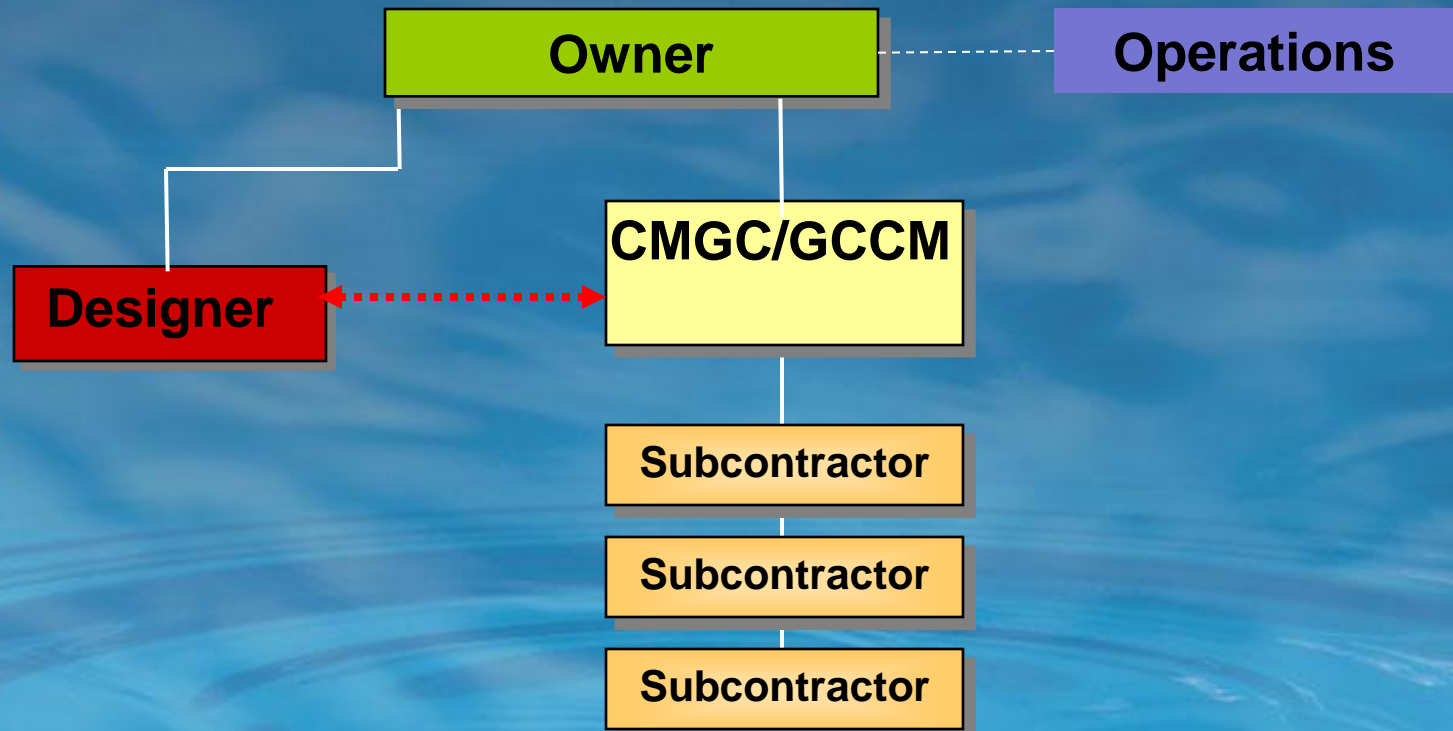

Role of CMGC/GCCM

- Provide constructability review
- Provide Cost Estimating
- Develop Construction Packages
- Manage and control execution of work
- Bid packages or self-perform
- Meet budget and schedule

In CMGC, Contractor is selected early and a Guaranteed Maximum Price is Set Between 30-90% Design

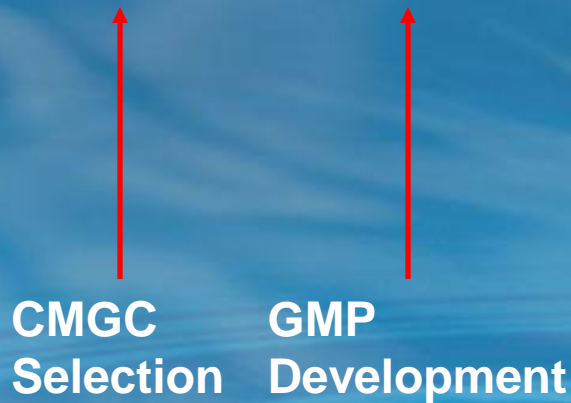
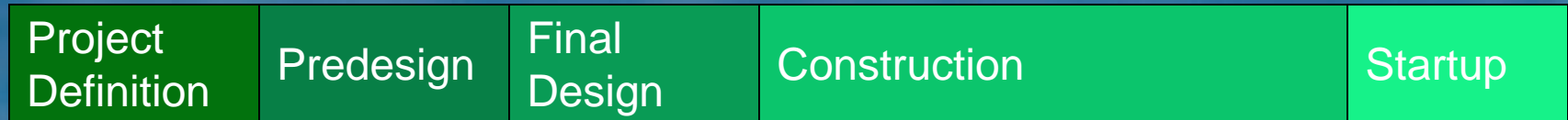

- Cost of work (open book)
- Agreed-upon contingency
- Competitively developed margin

Construction Packages are Competitively Bid and Constructed

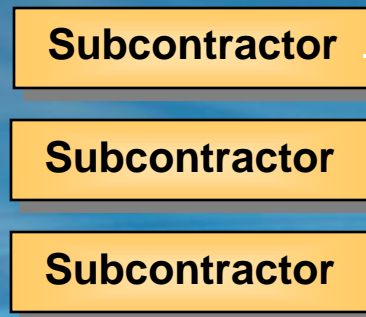
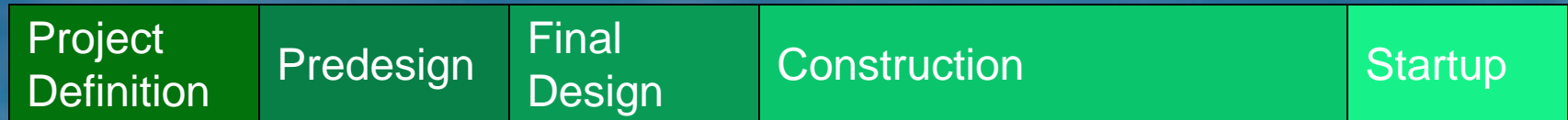

Option to self-perform

Final Cost > GMP: “Pain Share”
Final Cost < GMP: “Gain Share”

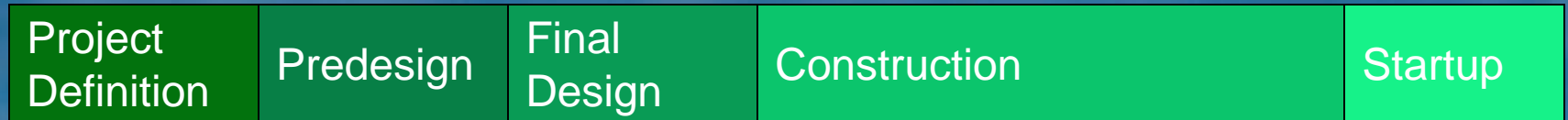

Final Cost

Why is CMGC Utilized?

- Most like traditional DBB
- Construction input into design process
- Earlier assurance of cost – depending on structure
- Contractor not selected on low-bid
- Easier to attract bidders

Typical Shortcomings of CMGC Approach

- Owner still in the middle between engineer and contractor
- Final contractor pricing can still often has “sticker shock” despite involvement

Design Build Integrates Engineering and Construction

Design – Build

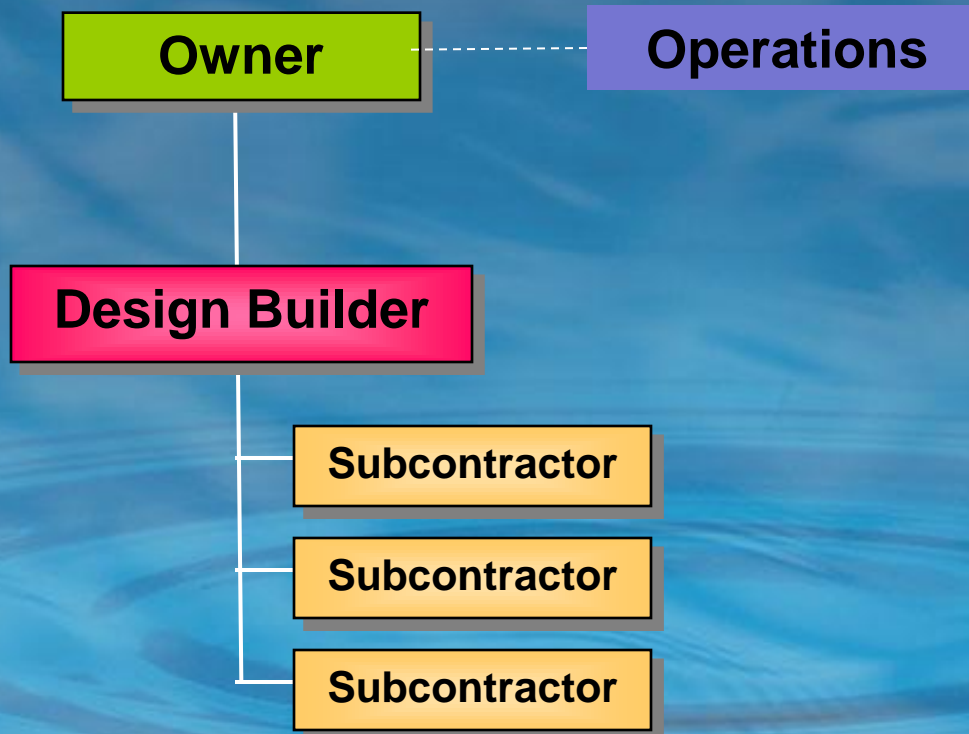

Why is Design/Build Typically Utilized?

- Owner gets out of the middle of designer and contractor
- One entity guaranties
 - price,
 - schedule,
 - quality,
 - performance
- Cost savings
 - less construction administration
 - shorter overall schedule

DBO Adds Operations to Single-Point Responsibility

**Design – Build -
Operate**

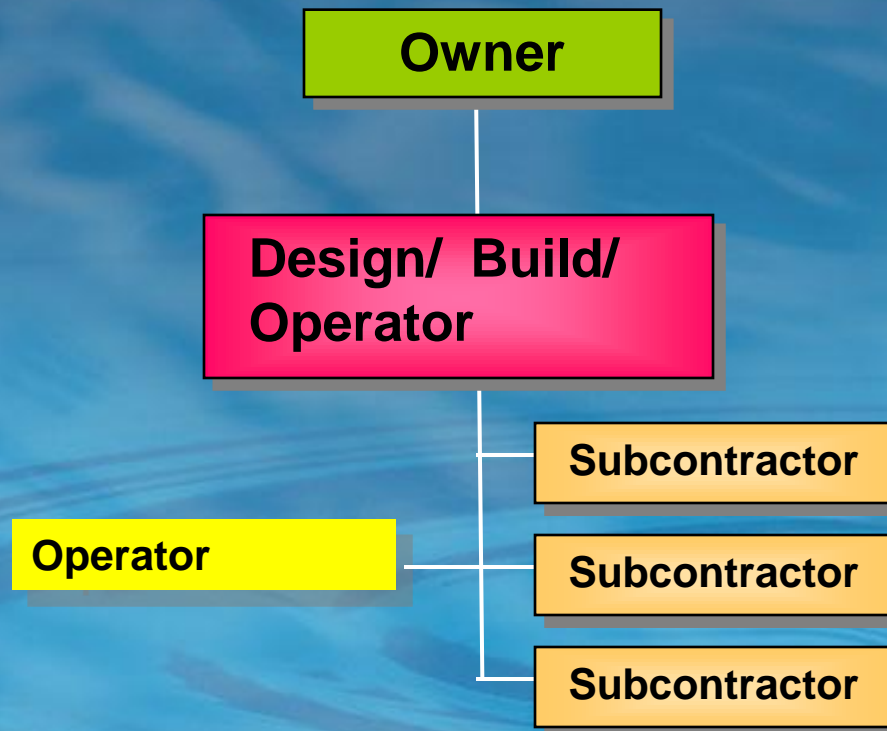

- Long-term warranty of performance
- Adds operations into integrated team
- Fixes long-term costs in addition to DB price, schedule, quality and performance guarantees

Why is DBO Typically Utilized?

- Owner wants long-term life-cycle costs to be basis of decision making
- Risk for long-term performance shifted to DBO operator
- Long-term operating costs fixed

Multiple variations on the DB/DBO theme tailors procurement to client needs



**Lump Sum /
bid**

**2 Step /
Phased /
GMP /
Progressive**

In Lump Sum DB/DBO, Price is Set at Time of Selection

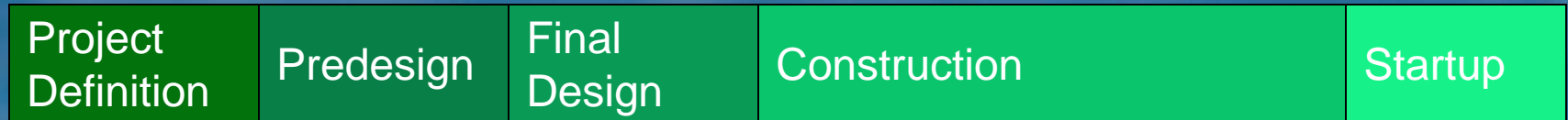

**Bid
Price**



- Allowances often used for undefined areas in bid

Performance or Prescriptive Lump Sum DB/DBO depending on amount of Owner-specified design

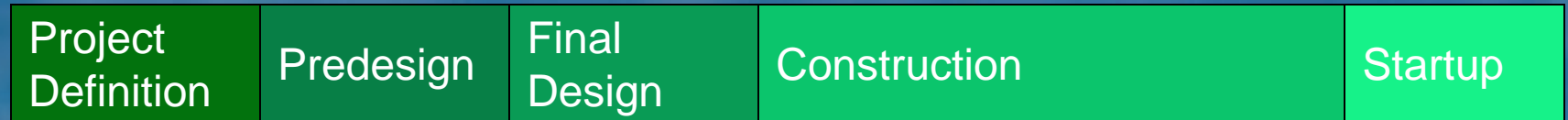

Performance Based

In Phased DB/DBO, Design is Progressed Before Price is Set

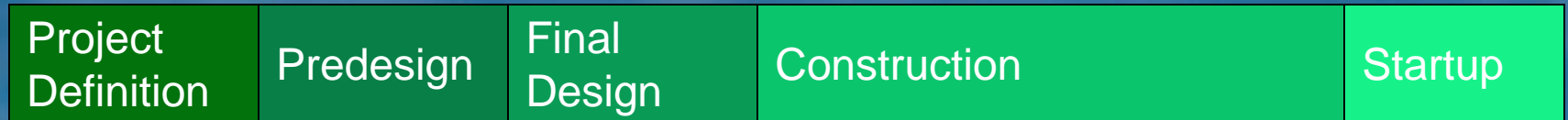

Selection

Price

Progressive DB is Like CMGC with same Designer & Contractor

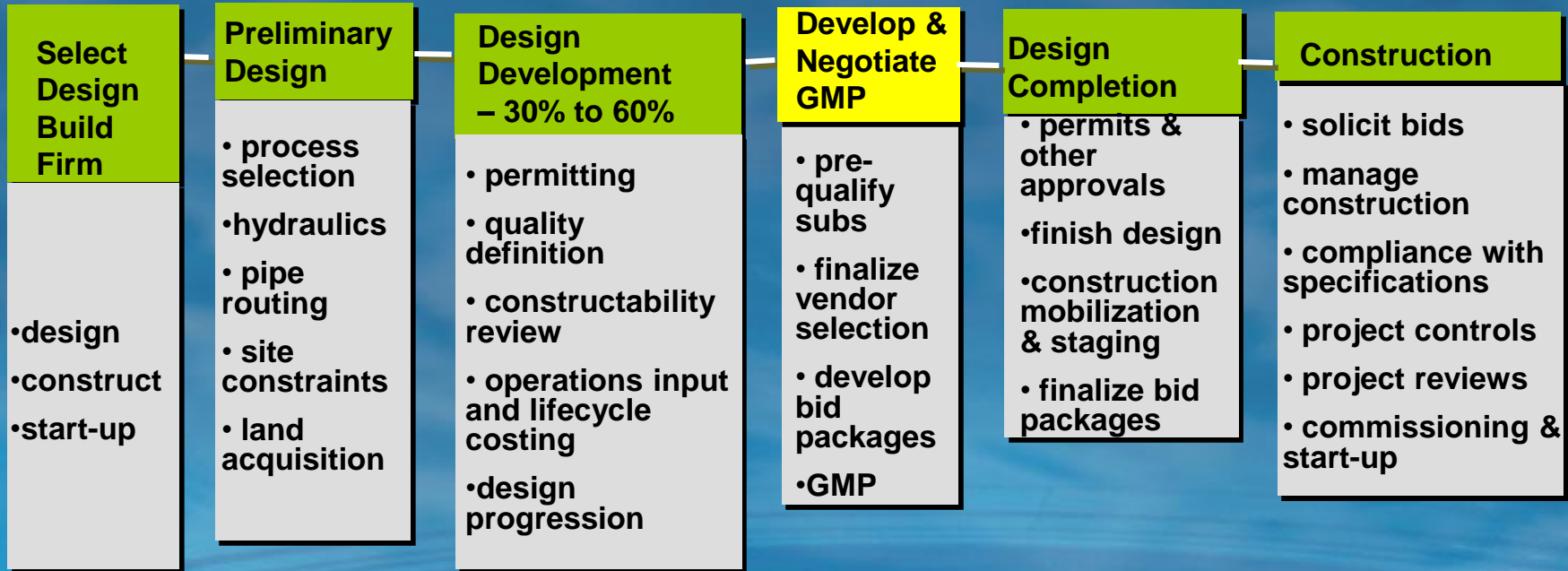

Agenda

- Brief Introduction to CH2M HILL
- Alternative Delivery Options
- Oregon and Washington Legal Context
- Things an Owner Should Consider

All forms of Alternative Delivery in Oregon are done as Exemption to Public Works Bidding

- Applicable rules in ORS 279C
- Must be unlikely to encourage favoritism or substantially diminish competition
- Must result in “substantial cost savings”

Three Steps are Required in Oregon to Utilize Alternative Delivery

- Prepare findings report to justify alternative delivery
- Hold a public hearing
- Prepare report after project is complete
 - Compare actual to estimated costs
 - Successes and failures
 - “Objective assessment” of results compared to findings

Findings Must Provide Justification for Decision to Use Alternative Delivery

- Operation, budget, financial data
- Public benefits
- Value engineering
- Specialized expertise required
- Public safety
- Market conditions
- Technical complexity
- Funding sources

Selection Process in Oregon for Alternative Delivery is Unconstrained

- Any desired procedure (qualifications, value, price)
- Consistent with local procurement policies

Two Types of Authority for Alternative Delivery in Washington

- RCW 70.150 – Service Agreements for Water Pollution Control Facilities
- RCW 39.010 – Alternative Delivery Procedure under Public Contracting

Service Agreements for WPCF's (RCW 70.150)

- Applicable only to water pollution control facilities
- Applicable to one or more of:
 - Design, construct, operate, finance, maintain, own

RCW 70.150 Administrative Requirements

- Formal selection process with evaluation criteria
- Department of Ecology review of final service agreement for compliance with certain other RCW's
- Public notice and hearing
- Finding that it is in "public interest" to enter into agreement

RCW 39.10 Authority:

Sunsets 2013 – Under Legislative Review!!!

- The Capital Projects Advisory Review Board (CPARB) established the Project Review Committee (PRC) to oversee alternative delivery
- PRC grants permission:
 - project specific approval
 - 3 year approval for any project that meets criteria
 - Application must show that agency has experience and qualifications to carry out the alternative delivery contracting

Alternative Public Contracting Not Restricted to WPCF Under RCW 39.10

- Design-build for projects greater than \$10,000,000, AND
 - design-build critical to construction or technology methodology; OR
 - design is repetitive or incidental to construction, OR
 - operator involvement not critical during design

Alternative Public Contracting Not Restricted to WPCF Under RCW 39.10

- GC/CM for any size project where
 - complex scheduling, phasing or coordination, OR
 - occupied facility that must continue operations during construction, OR
 - construction input during design critical to success, OR
 - complex or technical work environment, OR
 - historical structure

DB Selection under RCW 39.10

- Formal selection process with criteria
- Can be either “best value” or “lowest price” of responsive qualified bidders
- Honorarium required for losing bidders

GC/CM Selection Under RCW 39.10

- Formal process with evaluation criteria
- Negotiations with highest ranked respondent

Restrictions are Imposed by RCW 39.10 for GC/CM Execution

- Self-performance restricted to 30% of job, must be competitively bid, and work normally done by contractor
- Subcontracts must be competitively bid
- Maximum Allowable Construction Cost (MACC) set after 90% design documents

Agenda

- Oregon and Washington Legal Context
- Alternative Delivery Options
- Things an Owner Should Consider

What Issues Do Clients Typically Consider When Evaluating Delivery Models?

Issues:

Schedule

How can the procurement process be varied if schedule is critical?

Selection Criteria

What criteria are important to success?

What's the best indicator of future performance?

Design Effort

How much pre-design is required to ensure you get what you want (versus performance specifications)?

Price

How do you evaluate proposals beyond price?

Does low price always win?

Scope

What elements of the projects should be DB versus traditional delivery?

Design Approvals

How much oversight of design should you have?

Risk Sharing

How are risks best shared?

Quality

How do you ensure quality?

Control/Risk Sharing

Cost

Time

Complexity

The Project Delivery Spectrum Owner Comfort Zones

Owner maintains most control...and keeps most of the risk
result : owner gets prescribed project

DB/O firm assumes some control...and shares proportionate risk
result : owner gets defined performance



Control/Risk Sharing

Owner's

DB/O Firm's

(traditional)

(Alternative)

The Design-Build Spectrum

Owner Comfort Zones

Typical 5-year project involves multiple, discrete steps
result : predictability, traditional engineering

?

The same 5 year project might take 2 or 3 years involving parallel activities
result : team approach, joint responsibility, less time

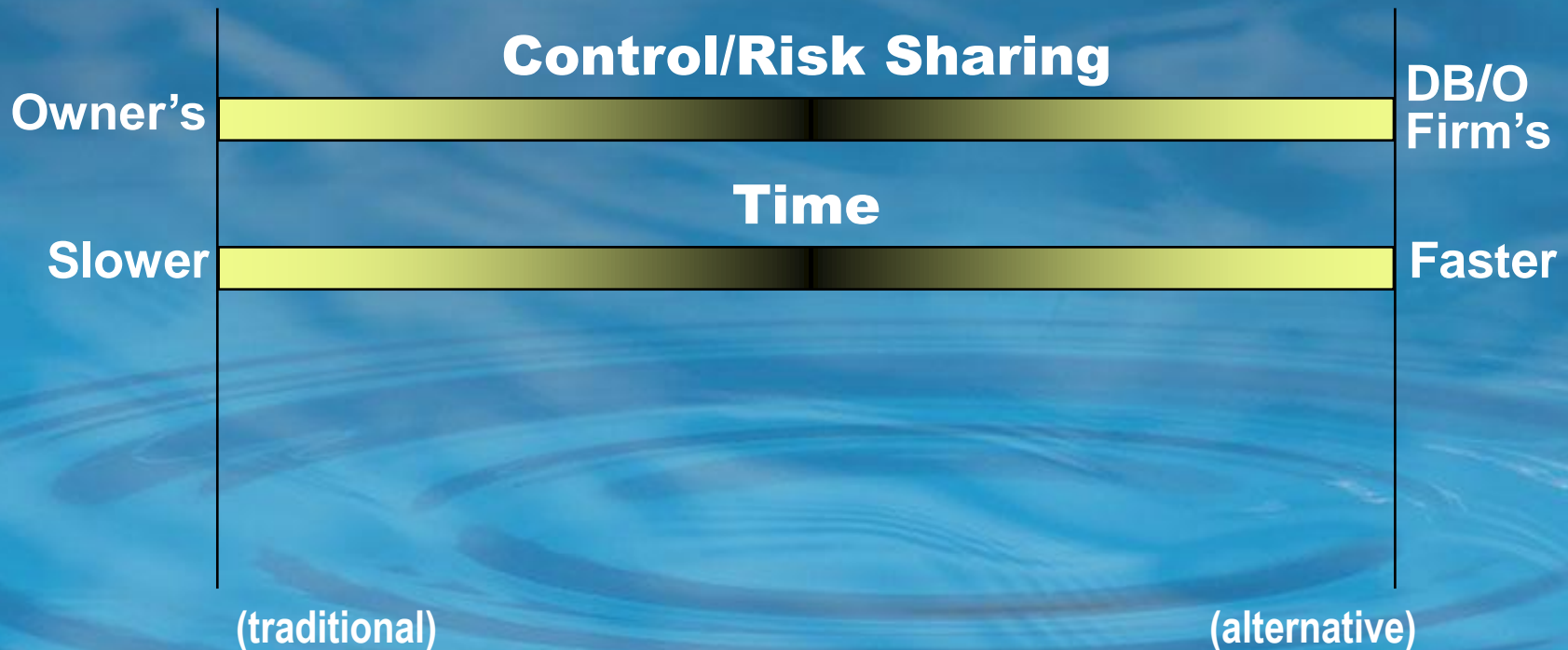

The Project Delivery Spectrum

Owner Comfort Zones

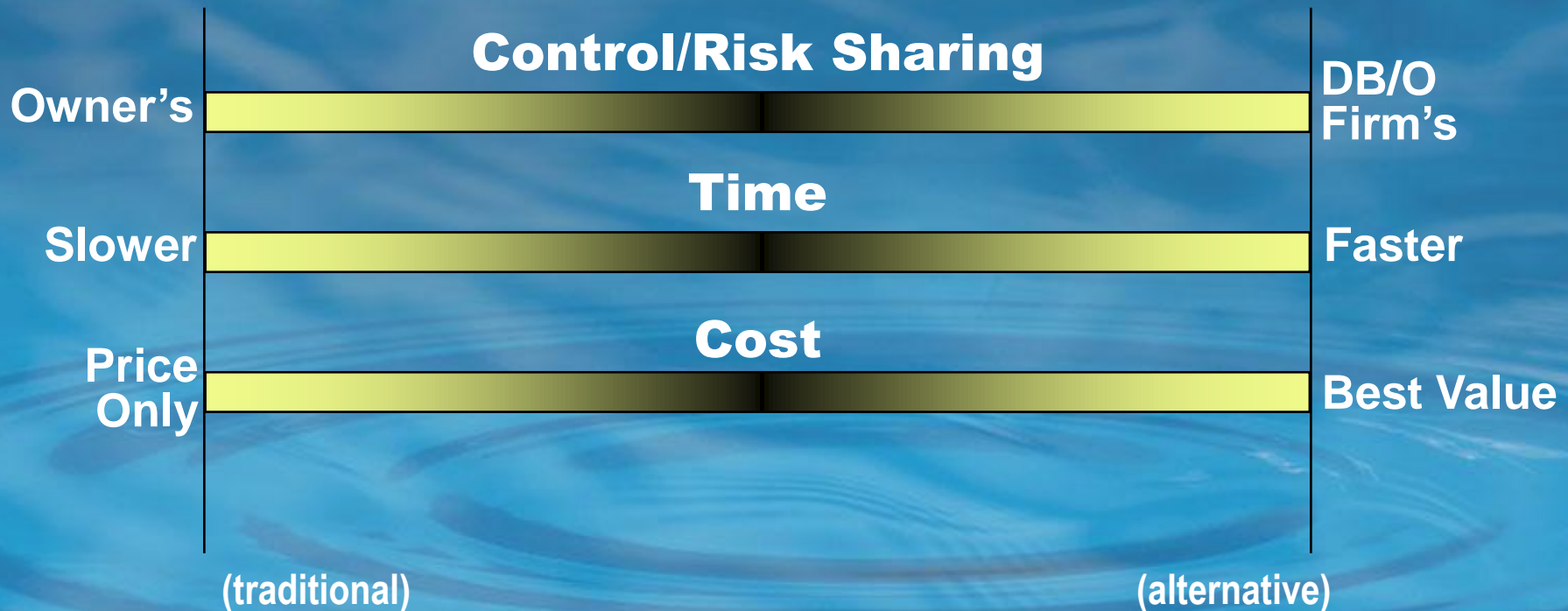
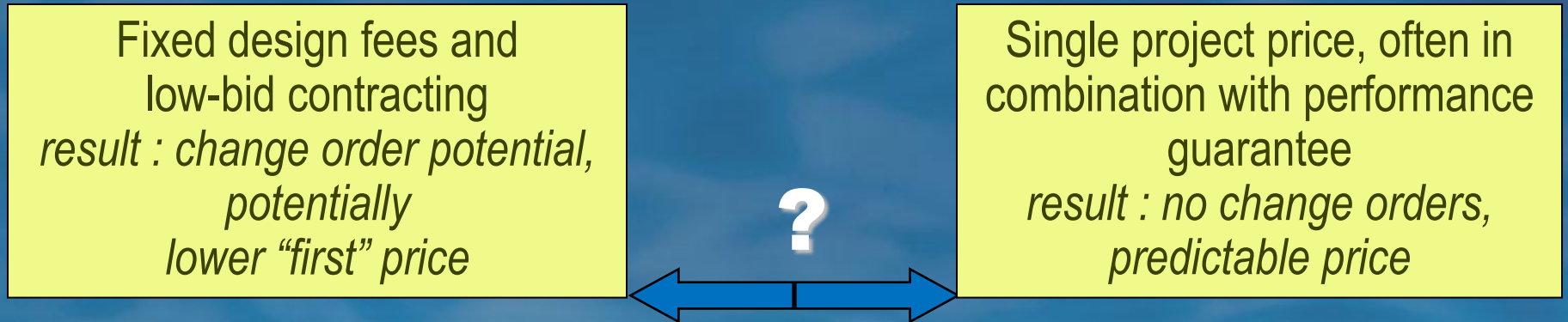

The Project Delivery Spectrum

Owner Comfort Zones

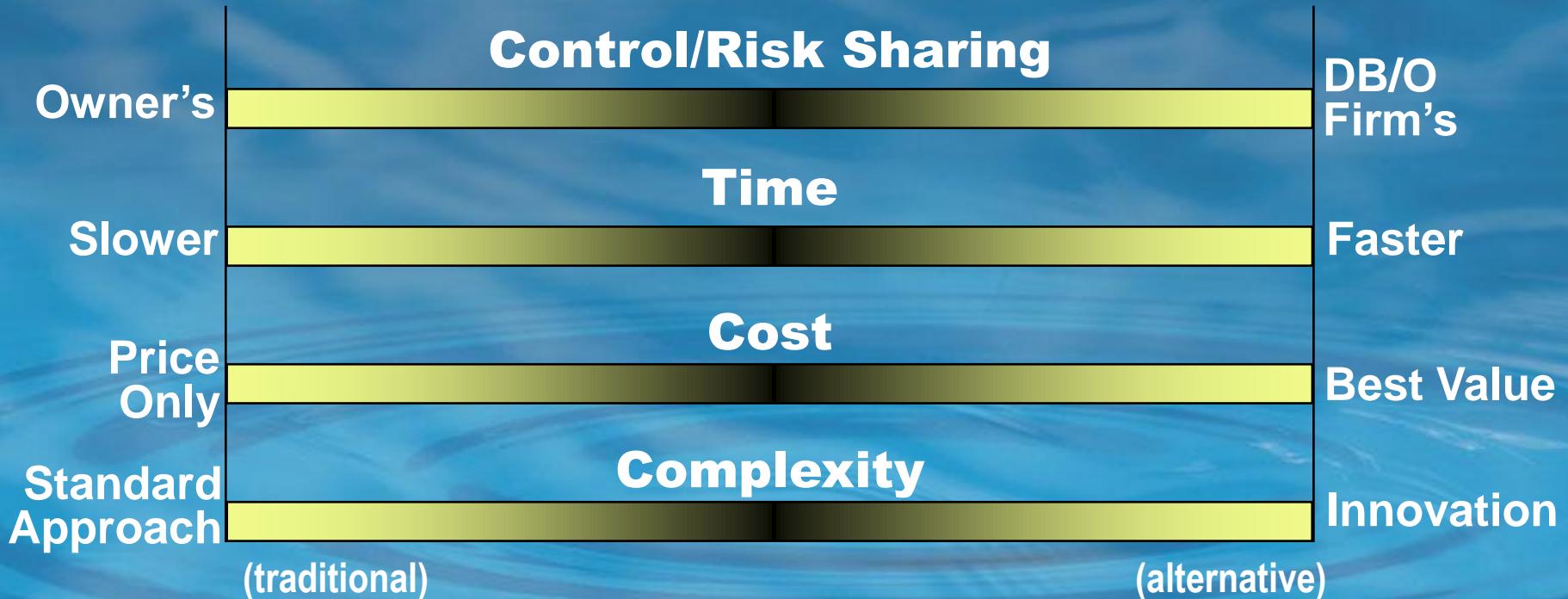
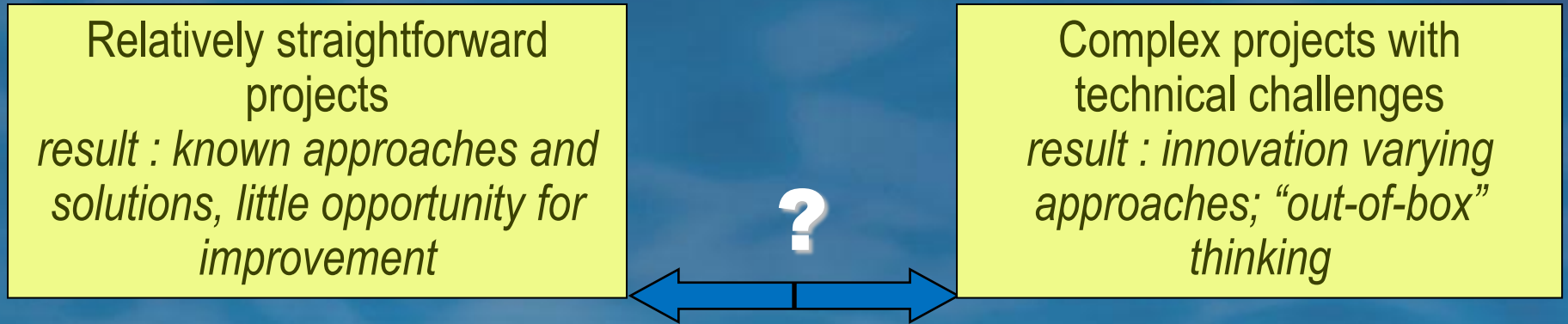

The Project Delivery Spectrum

Owner Comfort Zones

The project delivery for this profile...

...will be different than for this profile

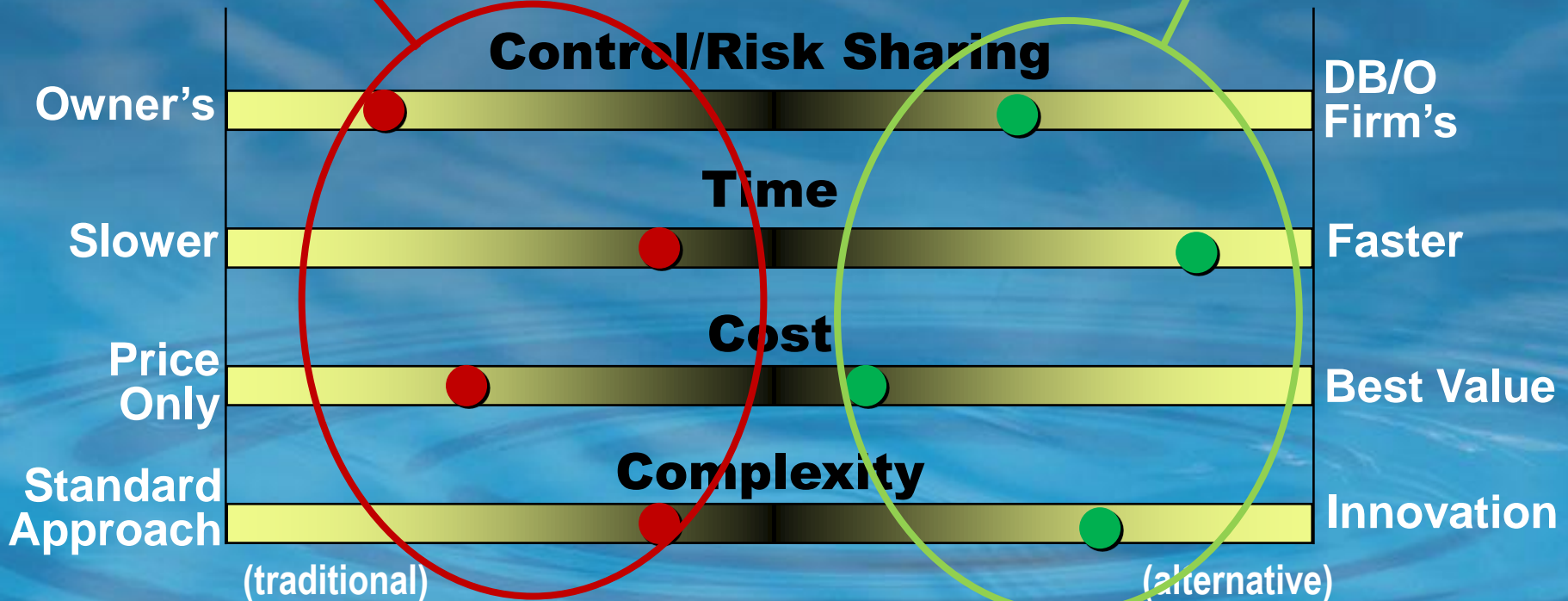
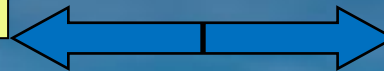

Whatever delivery option is best for an owner, it can be delivered!

PROJECT DELIVERY MODEL SPECTRUM

Design
Bid - Build

CMGC
GCCM

Design /
Build

Design/Build/
Operate

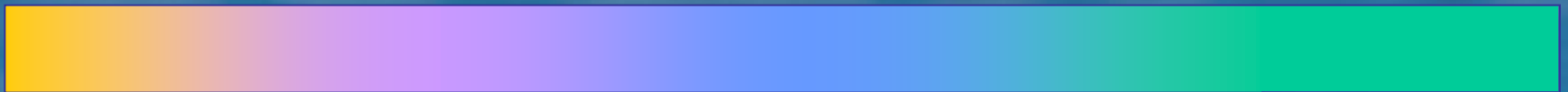

Pipelines

Pump Stations

Reservoirs

Treatment Plants

\$5 - \$10 M

\$200 - \$300 M

